

# Series 500 & 600

## Gas Mass Flow Instruments

### Digital Electronics Gives High Accuracy with Enhanced Performance:

Porter Series 500 Mass Flowmeters (MFM's) and Series 600 Mass Flow Controllers (MFC's) accurately measure and control (Series 600 only) flow rates of a wide variety of gases from 5 standard cubic centimeters per minute (SCCM) to 1000 standard liters per minute (SLPM) full scale nitrogen flow for operating pressures up to 3000 PSIG.

Series 500 MFM's and Series 600 MFC's feature performance-enhancing digital electronics, improved accuracy and repeatability, multi-gas capability and self-diagnostics. Both Series 500 and Series 600 are available with your choice of traditional analog inputs and outputs, an RS232 connection, Modbus, Profibus or DeviceNet digital protocol.



### Contact Information: Product Features:

Parker Hannifin Corporation  
**Porter Instrument Division**  
245 Township Line Road  
Hatfield, PA 19440

phone 215 723 4000  
fax 215 723 2199  
industrial@parker.com

[www.parker.com/porter](http://www.parker.com/porter)

- Digital Electronics
- Percentage of Reading Accuracy & Repeatability
- Multi-Gas Capability
- Analog I/O, RS232, Modbus, Profibus DP or DeviceNet Protocol
- Self-Diagnostics
- LED Operation Indicators
- Operating Pressures to 3000 PSIG
- Alarm and Counter Functions
- Remotely Adjustable Control Settings
- Single Power Supply Operation



ENGINEERING YOUR SUCCESS.

# Series 500 MFM's & 600 MFC's

## SPECIFICATIONS

**Flow Capacity:** Any flow range from 0-5 SCCM to 0-1000 SLPM (nitrogen equivalent).

Note: The flow ranges listed are the minimum and maximum nitrogen (N<sub>2</sub>) flow ranges available. Intermediate flow ranges are available. For correct sizing when operating parameters are questionable, please consult the factory.

**Response Time (per SEMI E17-91 Settling Time):** 1 to 2 seconds (consult factory for applications requiring faster response times)

**Accuracy and Linearity:** ±1.0% of reading (20%-100% full scale), ±0.8% of reading plus ±0.2% full scale (below 20% full scale)

**Repeatability:** Within ±0.2% of rate at any constant temperature within operating temperature range

**Rangeability (Control Range):** 50:1 (2%-100% full scale) (accuracy and control)

**Ambient and Operating Temperature Range:** -10 to 70°C (+14 to 158°F)

**Maximum Operating Pressure:**  
1500 PSIG (Models 511, 512, 513 & 514)  
1000 PSIG (Models 601, 602 & 651)  
200 PSIG (Models 602A, 603A & 604A)  
3000 PSIG (Models 521, 522, 523, 621 & 622)

**Temperature Coefficient (per SEMI E18-91 Zero Effect and Span Effect):**  
±0.05% full scale/°C of zero  
±0.05% of reading/°C of span

**Pressure Coefficient (per SEMI E28-92 Total Calibration Effect):** ± 0.1%/atmosphere typical using nitrogen (N<sub>2</sub>)

**Mounting Orientation:** Attitude insensitive

**Warm-up Time:** 10 minutes

**External Electrical Connector:** Nine (9)-pin D-connector (all units); RJ45 Modbus connector (units supplied with Modbus protocol)

**Setpoint Input/Flow Signal Output:**

Setpoint	Flow Signal
0-5 Vdc	0-5 Vdc (2K ohm minimum load resistance)
0-10 Vdc	0-10 Vdc (3K ohm minimum load resistance)
4-20 mAdc	4-20 mAdc (sourcing) (refer to load resistance values below)
0-100% (Modbus, Profibus DP, DeviceNet)	0-100% (Modbus, Profibus DP, DeviceNet)

Load resistance values for 4-20 mAdc flow signal output: 200-750 ohm for 15-30 Vdc loop supply voltage

**Power Supply Requirements (Current Consumption <250 mAdc):** All models operate from nominal power supply voltages of +15 or +24 Vdc

## MATERIALS OF CONSTRUCTION

**Body:** 316 Stainless Steel

**Sensor Assembly:** 316L Stainless Steel

**Orifice (MFC's only):** 316 Stainless Steel

**Valve Components (Wetted) (MFC's only):** 302 Stainless Steel, 316 Stainless Steel, 430F Stainless Steel and Sandvik® 1802

**Elastomers:** Buna N, EPDM, Kalrez®, Neoprene or Viton®

**Process Connections:** 316 Stainless Steel

*Sandvik® - AB Sandvik Materials Technology*  
*Kalrez®, Viton® - DuPont Dow Elastomers L.L.C.*

*Specifications subject to change*

## ORDERING INFORMATION

To order, please specify:

- Model number
- Type of output signal
- Elastomer material
- Process connection size & type
- Flow capacity
- Gas type
- Operating temperature
- Inlet (supply) pressure
- Outlet pressure (not required for MFM's)
- Calibration standard (i.e. 0°C, 20°C, 21.1°C or 25°C)
- Additional accessories required

# Model Number and Description

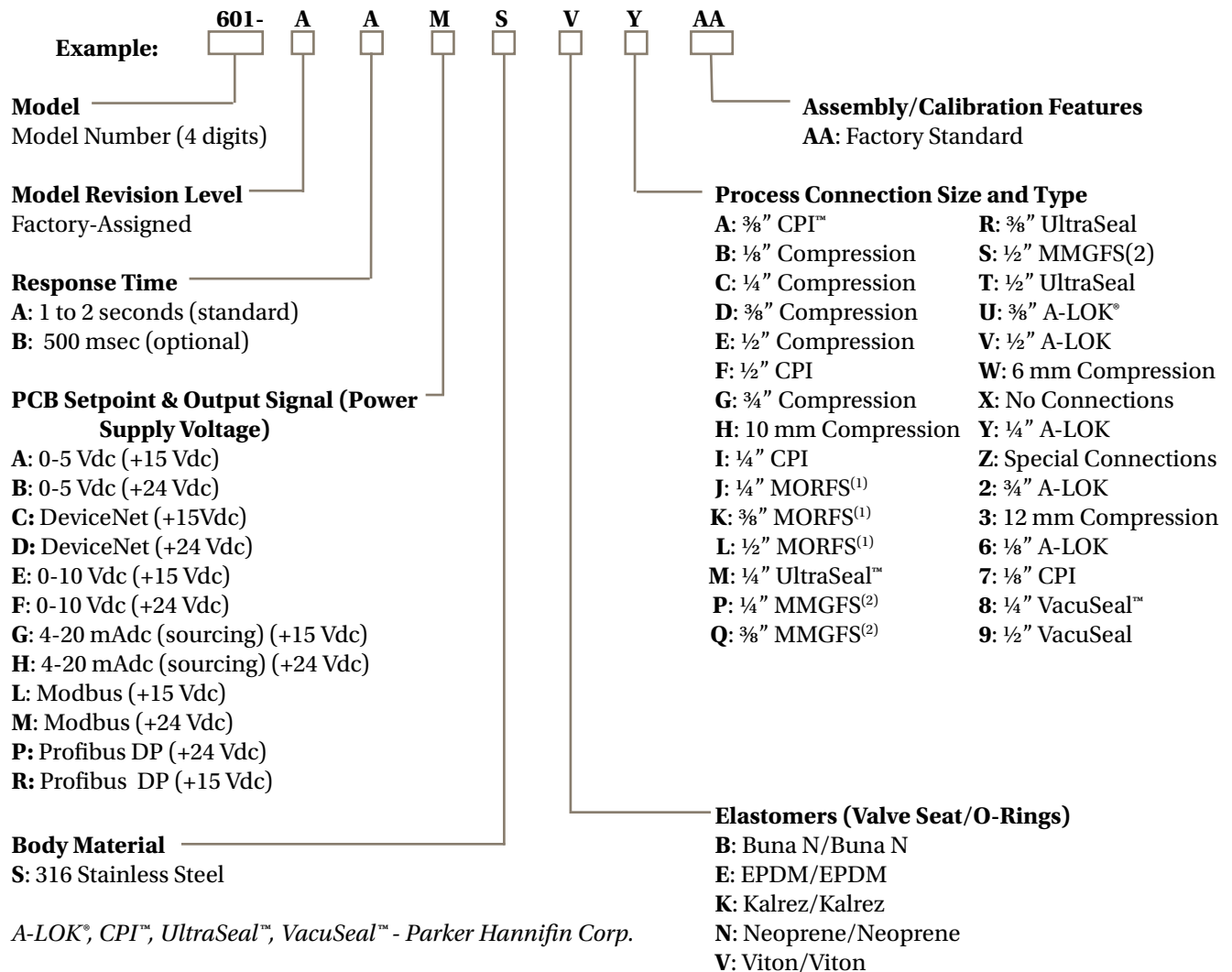

A-LOK®, CPI™, UltraSeal™, VacuSeal™ - Parker Hannifin Corp.

<sup>(1)</sup>MORFS = Male O-Ring Face Seal

<sup>(2)</sup>MMGFS = Male Metal Gasket Face Seal

For model number options not shown above, please consult factory

## Available Models

Note: The flow ranges listed are the minimum and maximum nitrogen (N<sub>2</sub>) flow ranges available for each given model. Intermediate flow ranges are available. For correct sizing when operating parameters are questionable, please consult the factory.

### Mass Flowmeters:

- Model 511: 0-5 SCCM to 0-10 SLPM N<sub>2</sub>
- Model 512: 0-10 SLPM to 0-100 SLPM N<sub>2</sub>
- Model 513: 0-100 SLPM to 0-500 SLPM N<sub>2</sub>
- Model 514: 0-500 SLPM to 0-1000 SLPM N<sub>2</sub>
- Model 521: 0-5 SCCM to 0-10 SLPM N<sub>2</sub>
- Model 522: 0-10 SLPM to 0-100 SLPM N<sub>2</sub>
- Model 523: 0-100 SLPM to 0-500 SLPM N<sub>2</sub>

### Mass Flow Controllers:

- Model 601: 0-5 SCCM to 0-10 SLPM N<sub>2</sub>
- Model 651: 0-10 SLPM to 0-50 SLPM N<sub>2</sub>
- Model 602: 0-10 SLPM to 0-100 SLPM N<sub>2</sub>
- Model 602A: 0-10 SLPM to 0-100 SLPM N<sub>2</sub>
- Model 603A: 0-100 SLPM to 0-500 SLPM N<sub>2</sub>
- Model 604A: 0-500 SLPM to 0-1000 SLPM N<sub>2</sub>
- Model 621: 0-5 SCCM to 0-10 SLPM N<sub>2</sub>
- Model 622: 0-10 SLPM to 0-100 SLPM N<sub>2</sub>

# Dimensional Data

## Series 500 Mass Flowmeters

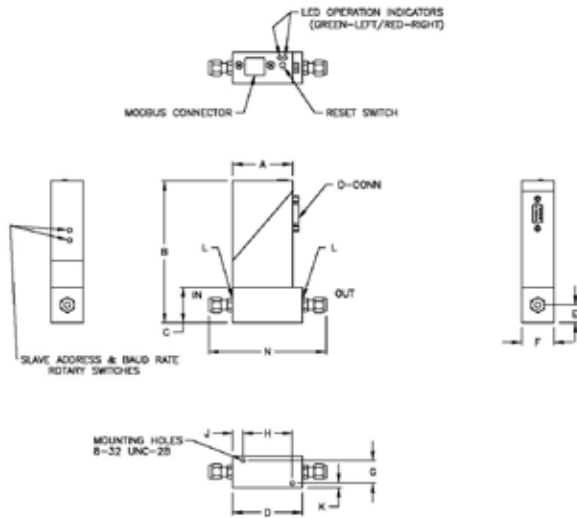

Model	511	512	513	514	521	522	523
A	1.83	1.83	1.83	1.83	1.83	1.83	1.83
B	4.520	5.145	5.895	5.895	4.520	5.145	6.645
C	1.125	1.750	2.500	2.500	1.125	1.750	3.250
D	2.187	2.564	3.739	5.174	2.187	2.564	4.055
E	.500	.875	1.250	1.250	.500	.875	1.625
F	1.000	1.750	2.500	2.500	1.000	1.750	3.250
G	.720	.828	1.318	1.318	.720	.828	1.318
H	1.540	1.862	2.953	2.953	1.540	1.862	2.953
J	.324	.511	.590	1.307	.324	.511	.906
K	.140	.461	.591	.591	.140	.461	.966
L	9/16-18	9/16-18	3/4-16	3/4-16	9/16-18	9/16-18	3/4-16
N	Refer to table below						

## Series 600 Mass Flow Controllers

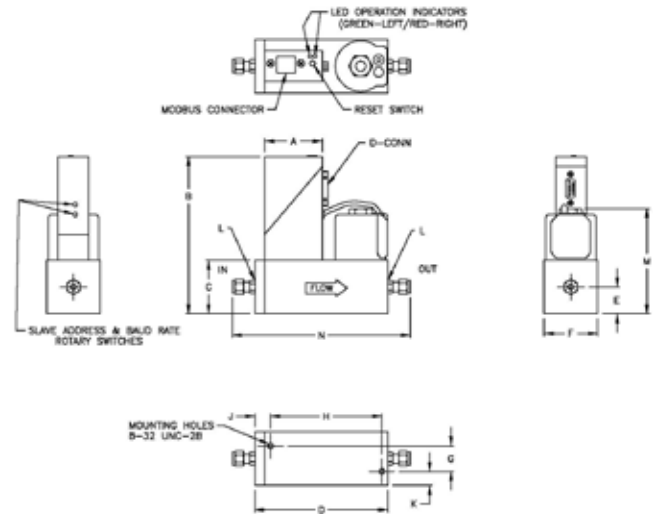

Model	601	602	602A	603A	604A	651	621	622
A	1.83	1.83	1.83	1.83	1.83	1.83	1.83	1.83
B	4.520	5.145	5.270	5.895	5.895	4.895	5.145	5.145
C	1.125	1.750	1.875	2.500	2.500	1.500	1.750	1.750
D	3.005	4.335	5.241	6.299	6.299	3.005	4.015	4.335
E	.500	.875	.875	1.250	1.250	.750	.875	.875
F	1.000	1.750	1.875	2.500	2.500	1.000	1.750	1.750
G	.720	.828	.828	1.318	1.318	.720	.828	.828
H	2.720	3.634	4.539	5.512	5.512	1.897	3.634	3.634
J	.145	.511	.511	.590	.590	.963	.191	.511
K	.140	.461	.523	.591	.591	.140	.461	.461
L	9/16-18	9/16-18	9/16-18	3/4-16	3/4-16	9/16-18	9/16-18	9/16-18
M	2.218	3.569	3.770	4.395	4.395	3.066	3.569	3.569
N	Refer to table below							

### Dimension 'N'

Model	511	512	513	514	521	522	523	601	602	602A	603A	604A	651	621	622	
A-LOK CPI	1/8"	4.027	N/A		4.027	N/A		4.845	N/A					5.855	N/A	
	1/4"	4.207	4.584	N/A		4.027	4.584	N/A	5.025	6.355	7.261	N/A		5.025	6.355	6.355
	3/8"	4.327	4.704	5.939	N/A	4.327	4.704	6.689	5.145	6.475	7.381	8.499	N/A	5.145	6.475	6.475
	1/2"	4.487	4.864	6.159	7.594	4.487	4.864	6.909	5.305	6.635	7.541	8.719	8.719	5.305	6.635	6.635
	3/4"	N/A		6.479	7.914	N/A		7.229	N/A		7.981	9.039	9.039	5.745	N/A	
VacuSeal	1/4"	4.067	4.444	N/A		4.067	4.444	N/A	4.885	6.215	7.121	N/A		4.885	6.215	6.215
	3/8"	4.367	4.744	6.179	7.614	4.367	4.744	6.929	5.185	6.515	7.421	8.739	8.739	5.185	6.515	6.515
	1/2"	4.367	4.744	6.179	7.614	4.367	4.744	6.929	5.185	6.515	7.421	8.739	8.739	5.185	6.515	6.515

N/A = Not Available

Dimensions shown in inches

For process connection options not shown, please consult factory